

DRUM 53L

Steel drum for storage and transport of batteries (lithium and non-lithium) packed together or in equipment.

Product information



Drum	
1	reinforcement rib
2	blind rivet
Lid	
3, 4 and 5	patented overpressure lid
4	flame arresting filter
6	clamping ring

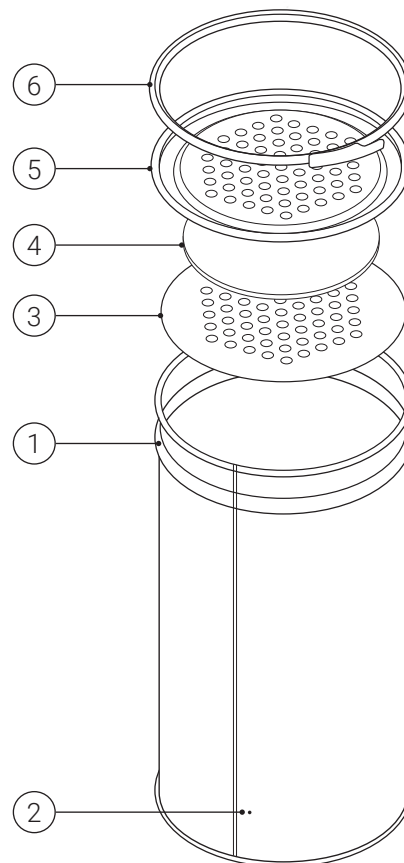
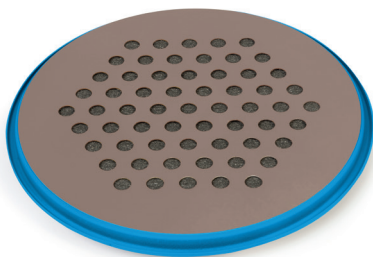

- For safe storage and transport **the lid must always be attached to the drum with the clamping ring.**
- **The lid is equipped with a flame arresting filter** that allows the lid to act as a venting device and to avoid flames coming out of the drum in case of an internal fire.
- **The blind rivet in the body of the drum is to regulate very small pressure differences** in the drum to avoid pressure on and loosening of the sticker on the lid.
- The drum has an **internal coating to avoid short circuit** due to contact of the battery with the metal.
- **The maximum stacking height is 3 drums.** Never stack the drums on top of each other to avoid blocking the overpressure system. Always use a pallet in between.
- **The drum is reusable after inspection** for possible damage and after cleaning.
- Any incident involving the drum must be reported to Bebat PRO.

The drums are UN certified:

Approved to transport dangerous goods within packing group I, II and III.

53 liter drum diameter 345 mm height 650 mm	
Classification under packing group	Max. gross mass
I	76 kg
II	114 kg
III	114 kg



1A2/X76/S/*
B/MF-210090
X76=Y114

